

Alfra Rotabest MAX 38 Plus Metal Core Drilling Machine



Operation Manual

1. Technical Data

Prod. – No.:	18553	
Name :	Rotabest Mini 36/50	
Input:	1050 Watt	
No-Load rpm:	400 rpm	
Tool Holder :	¾" (19 mm) Weldon	
Coolant supply:	internal, automatically	
Voltage:	(see nameplate)	
Magnetic Adhesion:	12000 N	
Boring Ø max. in Steel:		
- Core Cutter	38 mm	1 3/8"
- Twist Drills	10 mm	13/32"
Cutting Depth:	50 mm	2"
Stroke:	141 mm	5 9/16"
Size of Magnet Foot:	95 x 200 mm	3 ¾" x 7 7/8"

2. Description

- a) Motor
- b) Spindle
- c) Magnet Switch
- d) Motor Switch
- e) Weldon Arbor
- f) Magnet Foot
- g) Height Adjustment
- j) Recess for safety belt
- k) Adjusting screws for adjusting the slide

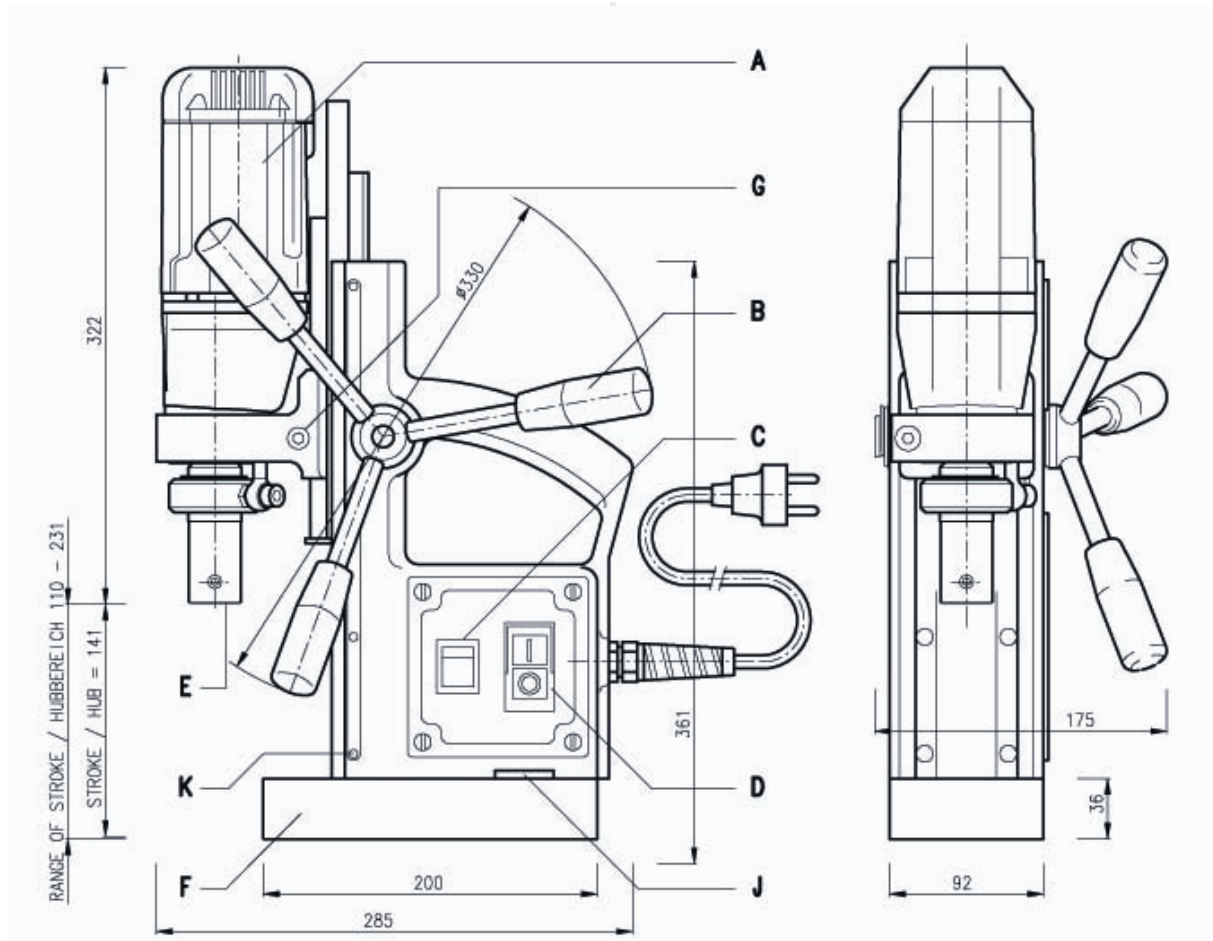

Standard scope of supply

- a) Transport Case
- b) Coolant Unit
- c) Safety Belt
- d) Allan Key 2,5 mm
- e) Allan Key 4,0 mm
- f) Allan Key 6,0 mm

Prior to use:



Read Operation Manual!



Pay attention to Safety Precautions!

Appropriate Use

This device is destined to:

Cut material with magnetizable surface with core cutters, twist drills and to tap threads in sheltered environment for commercial use industry and craft. The device is suitable for drilling vertical, horizontal and overhead.

3. Safety Precautions

Danger of Injuries

During drilling operations on walls and ceilings, the Metal Core Drilling Machine must be safeguarded with the included safety belt (f). **The magnetic adhesion is not maintained in case of a failure of circuit.**

The cut core will be ejected automatically by the ejector pin. **Danger of accident! The ejector pin could possibly break in case of improper use.**

Only use undamaged power cord and extension cords and regularly check on damages!

Power supply and voltage details at the device must correspond.

Personal protection equipment

When working with this device, wear the following protection equipment: Safety goggles, appropriate footwear, ear protection, hair net (for long hair), possibly also apron and safety helmet.

4. Precautions of use

The place of installation for the magnet foot must be clean and rustfree. Remove lacquer- and filler.

For non-magnetizable materials, please use the Rotabest Vacubest (Prod.- No. 18150).

Do not execute any electric welding on the workpiece, on which the Metal Core Drilling Machine is used.

The motor can be continuously adjusted on the slide by releasing the Allan screw (for a maximum enlargement of the stroke, when using twist drills, drill chucks or when tapping).



Prior to all operations, mount coolant unit (b).

Danger of injuries! Danger of an electric shock

For operations on walls and ceilings, we recommend cooling with our spray (Alfra BIO 2000, Prod.- No. 21010).

Switching on and off.

- Check connecting line and plug on damages first!
- Push switch “C” to initiate the magnet and the magnetic adhesion is guaranteed.
- When working on walls and ceilings, safe machine with safety belt (f).
- Push switch “D” to start the Motor.
- To switch off machine proceed in reverse order.

Change of tools

How to work with annular cutters.

- Push ejector pin (center pin) through head of annular cutter.
- Core drills with Weldon shank are tightened with clamping screws (DIN 913 M8 x 10) on both clamping surfaces.

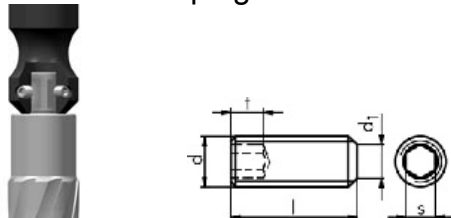

Core drills with RotaQuick shank are tightened with clamping screws (DIN 914 M8 x 10) in a countersinking, tighten the second clamp screw.

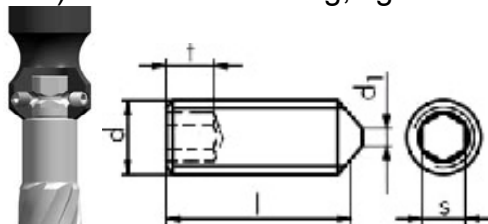

How to work with twist drills.

- The drill chuck is only to be used with twist drills
- Insert drill chuck with adaptor in the Weldon arbor (E).
- Insert twist drill in drill chuck and tighten.



Tapping

With the tapping attachments, it is possible to tap threads from M3-M12. The tapping attachments automatically switches over to left hand rotation, as soon as the hand wheel is turned back (B).



Operating tips.

First, place annular cutter with ejector pin on a marked center or marking. Drilling with ALFRA Rotabest cutters does not require much expenditure of force. Set the cutter and spot-drill, until the entire cut edge is formed as a circle.

During the drilling process, the cutter should be cooled permanently. Optimal Cooling is possible by internal cooling with our coolant unit.

During the drilling process, do not Stop the motor. After the process, cutter draw back with running motor.

Remove chips and core after each drilling. Remove chips with Chip-Remover – do not touch with bare hands – **DANGER OF INJURY!**

5. Cleaning.

Danger of injuries by unintentional switching on. Pull plug prior to cleaning.

Clean motor by means of dry compressed air (from the outside).

Check connecting lines on damages.

Clean and grease sliding surfaces regularly. Should, nevertheless, lateral play arise by wear of the dovetail guide, this could be adjusted by adjusting the laterally positioned set screws (K).

Carbon brushes should be replaced after appr. 250 hours running time.

After the work is finished, we recommend to store the Metal Core Drilling Machine in the transport case in a lying position.

6. Maintenance and repair.



Maintenance, check and repairs are only to be made by electronics specialists according to the valid regulations of the respective country.

The Metal Core Drilling Machine ALFRA ROTABEST should be serviced after appr. 250 hours running time by our Alfra workshop or appointed dealers.

Only use genuine ALFRA spare parts.

Spare part list at the end of this operation manual.

7. Accessories

	Alfra Rotabest HSS Co Core Cutter Ø 12 – 38 mm Cutting depth 25 mm Ø ½” – 1 3/8 mm Cutting depth 1”
	Center- and ejector pin Product –No. 1926500
	Alfra Rotabest HSS Co Core Cutter Ø 12 – 38 mm Cutting depth 50 mm Ø ½” – 1 3/8 mm Cutting depth 2”
	Center- and ejector pin Product –No. 1950500

	Alfra Rota Quick TCT Core Cutter Ø 14 – 35 mm Cutting Depth 35 mm Ø 11/16” – 1 3/8” Cutting Depth 1 3/8”
	Center- and ejector pin Product -No. 2001500
	Alfra Rota Quick TCT Core Cutter Ø 14 – 38 mm Cutting Depth 50 mm Product -No. 2003 0.. 050
	Center- and ejector pin Product -No. 2001501
	HSS Countersink and Deburrer Ø 25 mm Product -No. 18533 HSS Countersink and Deburrer Ø 40 mm Product -No. 18534
	Drill Chuck Ø 1-13 mm Product -No. 18107
	Attachment for clamping pipes Product -No. 18019
	Vacuum device Vacubest Product -No. 18150
	Coolant unit Product -No. 18104
	Alfra Bio 2000 Cutting Oil Product -No. 21010
	Alfra Magnetic Chip Remover Product -No. 18654

8. Guarantee

For our ALFRA Rotabest Metal Core Drilling Machines we grant guarantee according to the legal and regional regulations (proven by invoice).

9. CE Declaration of Conformity

We declare in our exclusive responsibility, that this product correspond to the following standards and specifications:

**Specification 89/392/EWG, 91/368/EWG
DIN EN 292 part 1 and 2
DIN EN 60204 part 1
DIN VDE 0740 T**

The proof of an electromagnetic compatibility took place according the appropriate EC-Specification 89/336/EWG after the following norms:

**EN 61000-3-2:1995/A1:1998/A2:1998
EN 61000-3-3:1995
EN 55014-1:1993/ A1:1997 55014-2:1997**

If the electric tool is modified without our authorization, this declaration will lose its validity and the guarantee expires.

The sound pressure level at the work place might exceed 85 dp(A). In case the user must wear hearing protectors.

10. Spare Parts

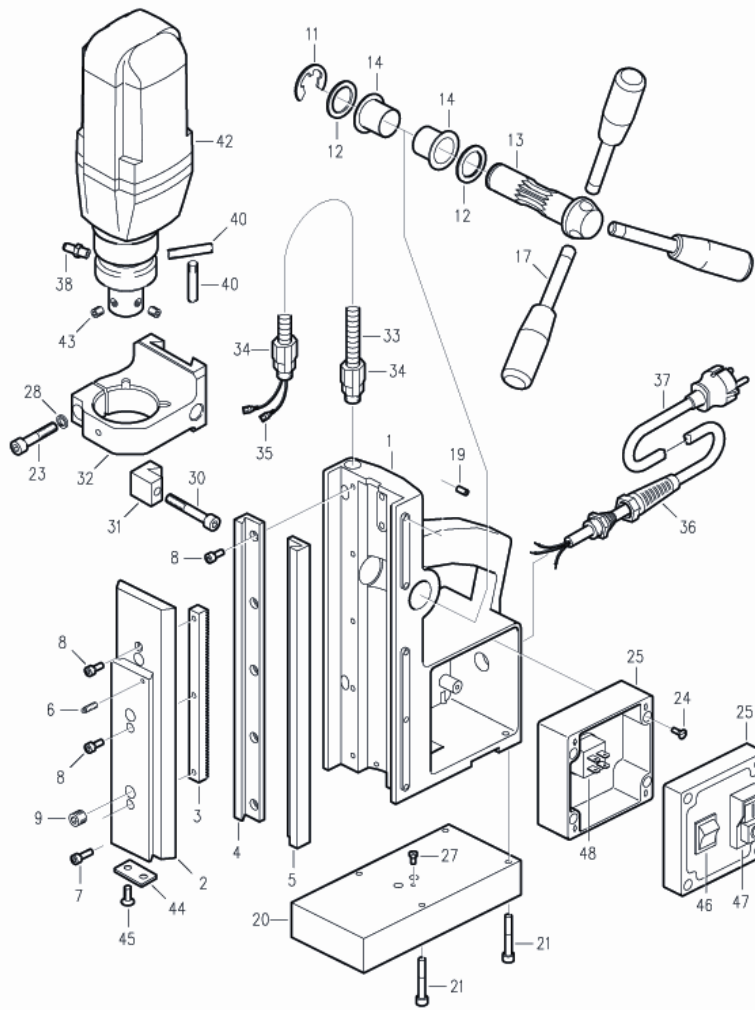

ROTABEST Mini 36/50

Änderungen vorbehalten

Item	Part N°	Pce
Pos.	Teile-Nr.	Menge
1	189501050	1
2	189501085	1
3	189501003	1
4	189501052	1
5	189501053	1
6	189030516A	1
7	189020516	1
8	189020512	12
9	189041210	3
11	189100019	1
12	189112535	2
13	189501056	1
14	189490502	2
17	189501060	3

19	189040510	5
20	189411020	1
21	189010640	1
22	189010645	3
23	189010840	1
24	189140416	4
25	189411055	1
27	189501062	1
28	189060008	1
30	189010850	1
31	189501076	1
32	189301089	1
33	189501033	1
34	189490603	2
35	189501035	1
36	189490602	1

37	189480276	1
37	189480276GB	
38	189302043	1
40	189301090	2
42	18214	1
42	18214.110	
44	189301090	1
45	189140616	2
46	189411056	1
47	189411057	1
47	189411057.110	
48	189411058	1
48	189411058.110	

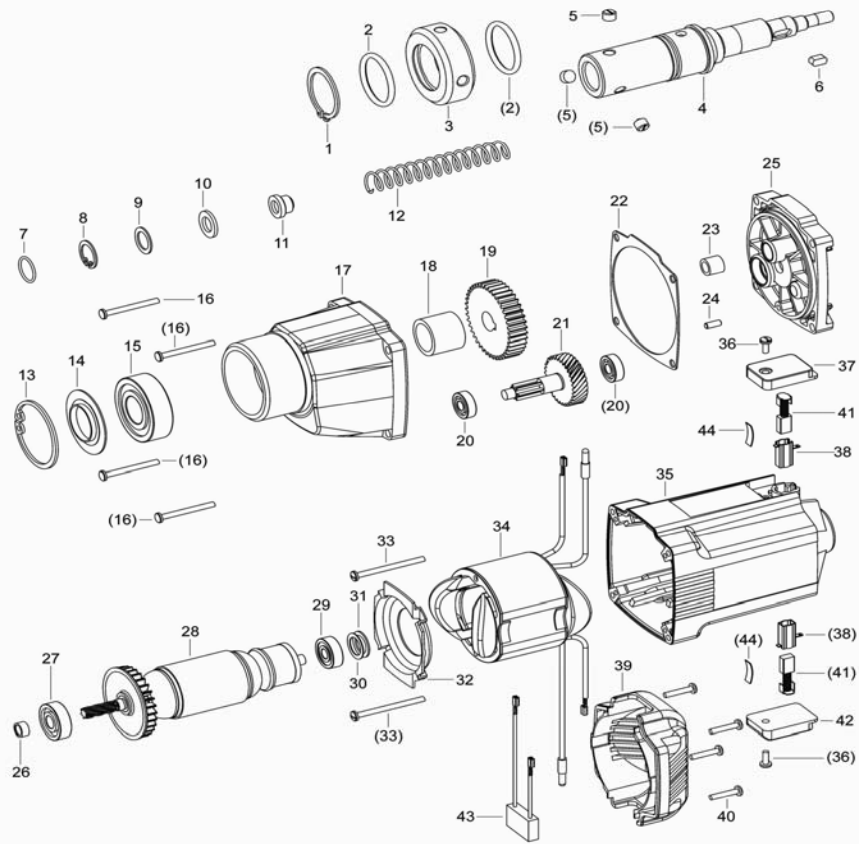

Item	Part N°	Pce
1	189311051	1
2	189311006	2
3	189311007	1
4	189311052	1
5	189621036	3
6	189311017	1
7	189311009	1
8	189311010	1
9	189311011	1
10	189311012	1
11	189311013	1
12	189311014	1
13	189311018	1
14	189311019	1
15	189311020	1

16	189311016	1
16	189311021	4
17	189311022	1
18	189311023	1
19	189311024	1
20	189311025	2
21	189311026	1
22	189311027	1
23	189311028	1
24	189311029	1
25	189311030	1
26	189311031	1
27	189311032	1
28	189311033	1
28	189311033.110	1
29	189311034	1

30	189311035	2
31	189311036	1
32	189311037	2
33	189311038	1
34	189311039	1
34	189311039.110	1
35	189311040	1
36	189311041	2
37	189311042	1
38	189311044	2
39	189311045	1
40	189311046	4
41	189311047	2
42	189311048	1
43	189311049	1
44	189311050	2